

THIS DRAWING IS UNPUBLISHED. RELEASED FOR PUBLICATION
 © COPYRIGHT - By TYCO ELECTRONICS CORPORATION. ALL RIGHTS RESERVED.

LOC	DIST	REVISIONS					
AF	50	P	LTR	DESCRIPTION	DATE	DWN	APVD
		N		REVISE PER ECR-13-013738	15FEB2014	GRZ	JL

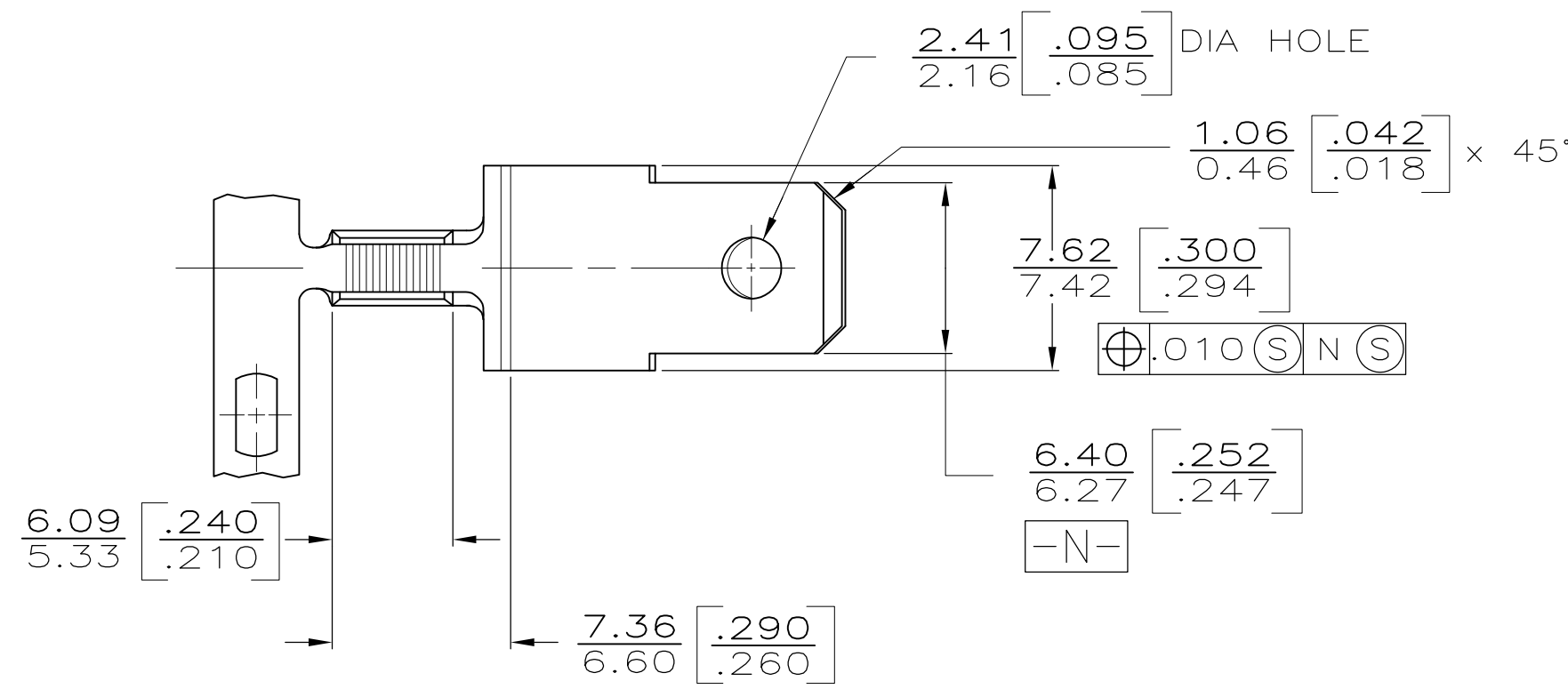

1- DIMENSIONS IN BRACKETS ARE IN INCHES.
 2- CONTINUOUS STRIP ON REELS.

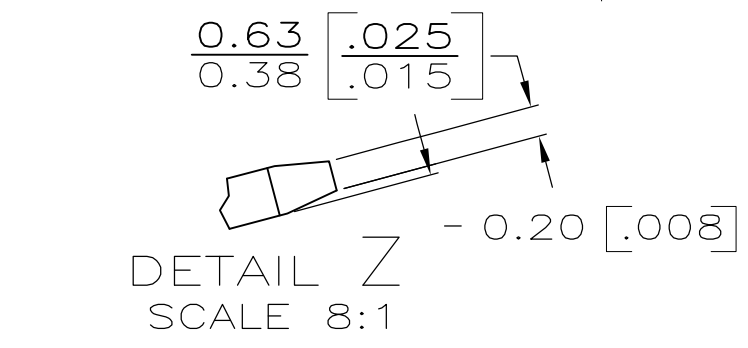
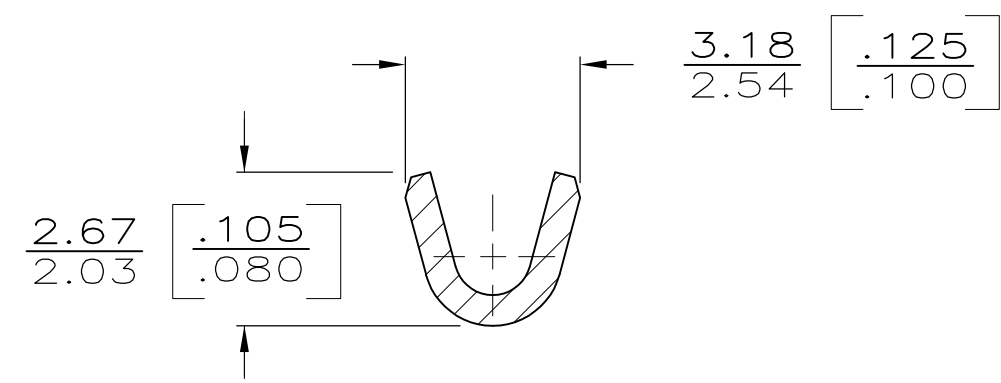
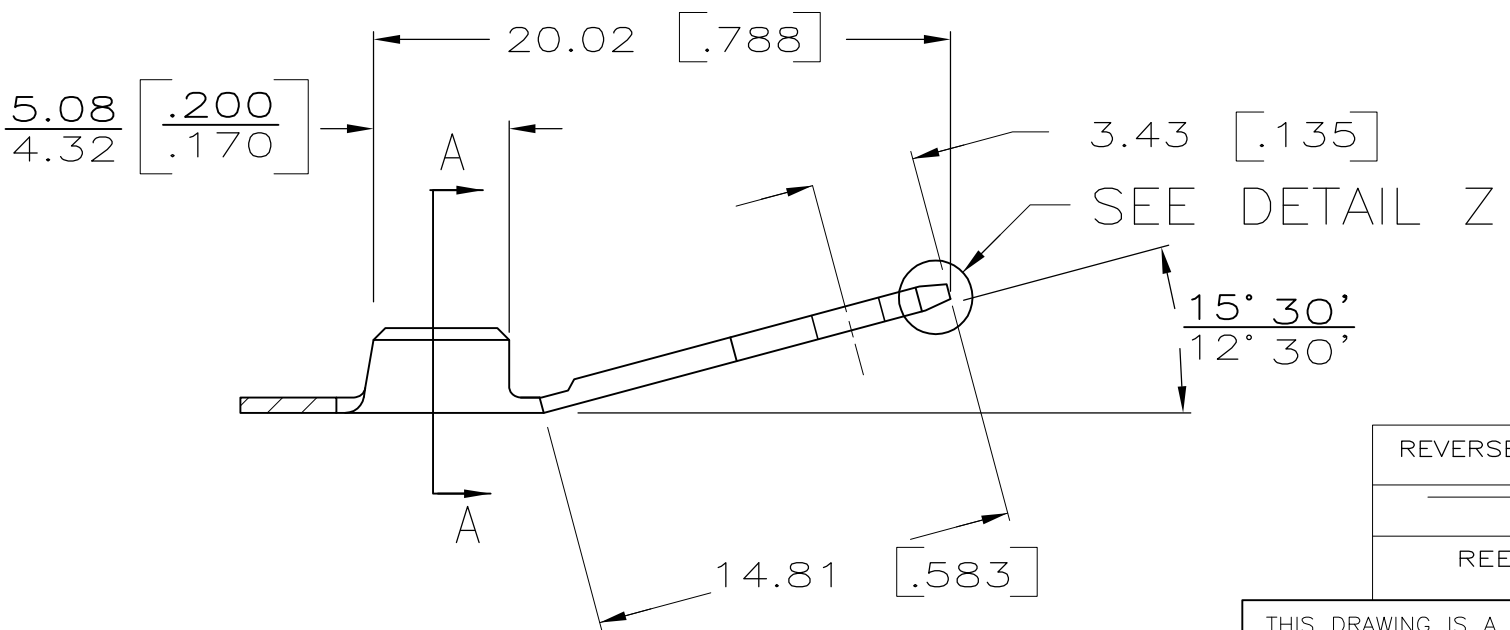

METRIC

REVERSE REEL	0.81 ^{±0.025} $\left[.032 \right]$ ±.001 PRE-MILLED	0.91-0.57 MM DIA	63165-2
	TO 0.51 ^{±0.025} $\left[.020 \right]$ ±.001	$\left[19-23 \right]$	63165-1
REELING	MATERIAL	WIRE BARREL	PART NUMBER

THIS DRAWING IS A CONTROLLED DOCUMENT.		DWN JR RUTH 3-21-86	STE TE Connectivity	
DIMENSIONS: INCHES		CHK G YETTER 3-21-86		
TOLERANCES UNLESS OTHERWISE SPECIFIED:		APVD C MEYERS 3-21-86		
0 PLC ± - 1 PLC ± - 2 PLC ± - 3 PLC ± .010 4 PLC ± - ANGLES ± -		NAME R KUZO 3-21-86		
MATERIAL BRASS	FINISH TIN	PRODUCT SPEC	.250 FASTON AMPLIVAR TAB	
		APPLICATION SPEC	SIZE A3	CAGE CODE 00779
		WEIGHT -	DRAWING NO C-63165	RESTRICTED TO -
CUSTOMER DRAWING			SCALE NTS	SHEET 1 OF 1
			REV N	